

WARRANTY

All Legend ® Suspensions' parts are guaranteed to the original purchaser to be free of manufacturing defects and workmanship. Parts that fail to conform to these conditions will be repaired or replaced at Legend ® Suspensions' option if the parts are returned to Legend ® Suspensions by the original purchaser. Delivery of the original purchase invoice or receipt along with the part to Legend ® Suspensions is a condition precedent to Warranty coverage. Warranty coverage is limited lifetime.

In the event the original purchaser believes warranty service is required, the original purchaser must call or e-mail Legend ® Suspensions immediately to discuss the concern. Some concerns may be rectified by a telephone call and need no further course of action.

A part that is suspect of being defective must not be replaced by a Dealer or any other person without prior written authorization from Legend ® Suspensions. If it is deemed necessary for Legend ® Suspensions to make an evaluation of the part to determine whether a defect exists, a return authorization number (RA#) must be obtained from Legend ® Suspensions by the original purchaser. Properly obtaining a return authorization number from Legend ® Suspensions is a condition precedent to Warranty coverage.

The part must be packaged properly so as to not cause further damage and be returned prepaid to Legend ® Suspensions with a copy of the original invoice or receipt of purchase. If after evaluation, Legend ® Suspensions finds the part to be defective, Legend ® Suspensions will repair or replace the part, at the discretion and option of Legend ® Suspensions.

Exclusions

This warranty is void if:

(1) the Legend ® Suspensions' part is repaired, modified or altered, unless such repair, modification or alteration is expressly authorized by Legend ® Suspensions in writing;

(2) the Legend ® Suspensions' part becomes defective in whole or in part as a result of improper installation, improper maintenance, improper use, abnormal operation, or any other misuse or mistreatment of the Legend ® Suspensions' part;

(3) the Legend ® Suspensions' part is installed or used in any motorcycle or other vehicle other than an Unmodified Factory OEM Motorcycle;

(4) the Legend ® Suspensions' part is installed or used on any motorcycle or other vehicle being used in any form of competitive riding or racing, off road riding, or stunt riding. Stunt riding shall include, but not be limited to, any form of acrobatic maneuvering of the motorcycle, wheelies, stoppies, burnouts, jumping, or operating the motorcycle at an excessive rate of speed;

(5) the Legend ® Suspensions' part is installed or used on any motorcycle or other vehicle being operated at a speed in excess of the speed allowed by any applicable law, regulation, or ordinance or is operated in any other manner in violation of any applicable law, regulation or ordinance;

(6) the serial or parts identification number of the Legend ® Suspensions' part is defaced or missing;

(7) the Legend ® Suspensions' part is returned with no authorization number issued from Legend ® Suspensions; or

(8) the original purchase invoice or receipt is not provided to Legend ® Suspensions along with the part.

Additional Limitations

(1) Legend ® Suspensions shall have no warranty or liability obligation to cover work shop labor charges incurred to install or remove suspension systems or individual components.

(2) Electrical components are limited to a two-year manufacture's warranty from the original invoice date or installation.

(3) Limited lifetime warranty as used within this warranty is further defined as the lifetime of the specific product line. Any product line that has been discontinued for which replacement parts are no longer available by is not covered by this warranty.

(4) The customer is liable for shipping charges to and from Legend ® Suspensions for warranty repairs or replacement parts consistent with this warranty. LEGEND ® SUSPENSIONS (INCLUDING ITS SUBSIDIARIES, AFFILIATES, OFFICERS, DIRECTORS, EMPLOYEES, AGENTS OR SHAREHOLDERS) SHALL NOT, UNDER ANY CIRCUMSTANCES, WHETHER AS A RESULT OF BREACH OF CONTRACT, BREACH OF WARRANTY, TORT, STRICT LIABILITY, THE FAILURE TO DELIVER, DELAY IN DELIVERY IN NONCONFORMING CONDITION, OR FOR ANY OTHER BREACH OF CONTRACT OR DUTY BETWEEN LEGEND ® SUSPENSIONS AND A CUSTOMER OR OTHERWISE, BE LIABLE FOR CONSEQUENTIAL, INCIDENTAL, SPECIAL OR EXEMPLARY OR PUNITIVE DAMAGES INCLUDING, WITHOUT LIMITATION, LOSS OF PROFITS OR REVENUES, LOSS OF OTHER GOODS OR ASSOCIATED EQUIPMENT OR DAMAGES

TO ANY ASSOCIATED EQUIPMENT, COST OF CAPITAL OR LABOR, COST OF REPLACEMENT OR SUBSTITUTE PRODUCTS, OR LOSS OF TIME. IN THE EVENT THAT LEGEND ® SUSPENSIONS SHALL BE UNABLE TO REPAIR OR REPLACE THE PRODUCT AS REQUIRED HEREIN, THE LIABILITY OF LEGEND ® SUSPENSIONS TO YOU OR ANY OTHER PARTY SHALL NOT EXCEED THE PRICE ACTUALLY PAID BY YOU FOR THE PRODUCT, UPON THE PAYMENT OF WHICH, LEGEND ® SUSPENSIONS SHALL BE RELEASED FROM AND DISCHARGED OF ALL FURTHER OBLIGATIONS AND LIABILITY TO YOU.

THIS LIMITED WARRANTY GIVES YOU SPECIFIC LEGAL RIGHTS, AND YOU MAY ALSO HAVE OTHER RIGHTS THAT VARY FROM STATE TO STATE. SOME STATES DO NOT ALLOW THE EXCLUSION OR LIMITATION OF INCIDENTAL OR CONSEQUENTIAL DAMAGES, SO THE ABOVE LIMITATION OR EXCLUSION MAY NOT APPLY TO YOU.

WARNING: Legend ® Suspensions recommends this system be installed by a professional technician with professional knowledge of disassembly / reassembly procedures and post installation checks. Legend ® Suspensions are designed to be installed and used on Unmodified OEM Motorcycles only. Legend ® Suspensions assumes no responsibility for damage or injuries which may result from the use or installation of its products, whether or not properly installed or used. Installing a Legend ® Suspension may decrease initial ground clearance when in lowered position. The motorcycle will be lower to the ground and care should be taken to avoid bottoming out, especially over bumps or in turns. To maintain proper balanced geometry, we recommend riding in the stock height position.

Dispute Resolution

You agree that any dispute between you and Legend ® Suspensions arising hereunder will be resolved exclusively and finally by arbitration administered by the American Arbitration Association ("AAA") and conducted under its rules, except as otherwise provided below.

The arbitration will be conducted before a single arbitrator and will be limited solely to the dispute between you and Legend ® Suspensions. The arbitration shall be held at any reasonable location in Meade County, South Dakota, or by submission of documents, by telephone, online or in person. Any decision rendered in such arbitration proceedings will be final and binding on each of the parties, and judgment may be entered thereon in any court of competent jurisdiction. Should either party bring a dispute in a forum other than AAA, the arbitrator may award the other party its reasonable costs and expenses, including attorney fees and disbursements incurred in staying or dismissing such other proceedings or in otherwise enforcing compliance with this dispute resolution provision.

YOU UNDERSTAND THAT YOU WOULD HAVE HAD A RIGHT TO LITIGATE DISPUTES THROUGH A COURT, AND THAT YOU HAVE EXPRESSLY AND KNOWINGLY WAIVED THAT RIGHT AND AGREED TO RESOLVE ANY DISPUTES THROUGH BINDING ARBITRATION.

For the purposes of this section, the term "dispute" means any dispute, controversy, or claim arising out of or relating to: (1) this Agreement, its interpretation, or the breach, termination, applicability or validity thereof, or (2) the purchase or use of any Product, Accessory, service or otherwise from Legend ® Suspensions.

For purposes of this Agreement, the term Legend ® Suspensions means Legend ® Suspensions, its subsidiaries, affiliates, directors, officers, employees, beneficiaries, agents or assigns; the term "you" means you, the original purchaser, your agents, beneficiaries, or heirs.

Governing Law

Both you and Legend ® Suspensions consent to the application of the laws of the State of South Dakota to govern, interpret, and enforce all of your rights and Legend ® Suspensions' rights, duties, and obligations arising from, or relating in any manner to, the subject matter of this Limited Lifetime Warranty, without regard to conflict of law principles.

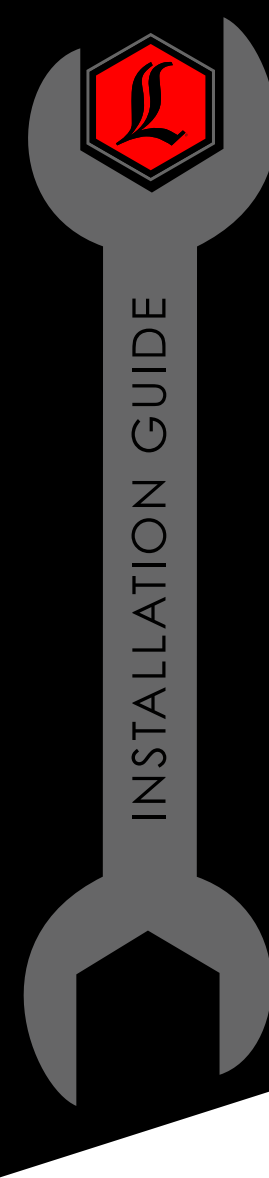

REVO ARC REMOTE RESERVOIR BILLET EXTERNAL MOUNT KIT

**FITMENT:
2014-2023 HARLEY-DAVIDSON
FLH TOURING MODELS**

OUR PRODUCTS ARE PROUDLY MADE IN THE USA



For customer service e-mail service@legendsuspensions.com

For additional help visit [youtube.com/legendsuspensions](https://www.youtube.com/legendsuspensions)

English

Please scan the QR code to access product install guides and warranty in your selected language.

Spanish

Escanee el código QR para acceder a las guías de instalación del producto y a la garantía en el idioma seleccionado.

German

Bitte scannen Sie den QR-Code, um auf Produktinstallationsanleitungen und die Garantie in der von Ihnen ausgewählten Sprache zuzugreifen.

French

Veillez scanner le code QR pour accéder aux guides d'installation et à la garantie du produit dans la langue de votre choix.

Italian

Scansionare il codice QR per accedere alle guide di installazione del prodotto e alla garanzia nella lingua selezionata.

Please scan the QR code to access product install guides and warranty in your selected language.



INSTALL INSTRUCTIONS



STEP ONE: INSTALL SHOCKS

A. Install the shocks according to the instructions provided with your Legend Suspensions Revo-ARC kit.



STEP TWO: INSTALL SUPPORT ARMS

- Identify the LH and RH reservoir support arms as shown in **FIGURE A**.
- Remove the fender strut bolts as shown in **FIGURE B**.
- Apply blue threadlocker to the provided mounting screws.
- Mount reservoir support arms to the fender strut as shown in **FIGURE C & D** using the notes and the images provided below and on the next page for your year, model, and configuration.
- Torque the 5/16"-18 mounting screws to 22 ft-lbs.

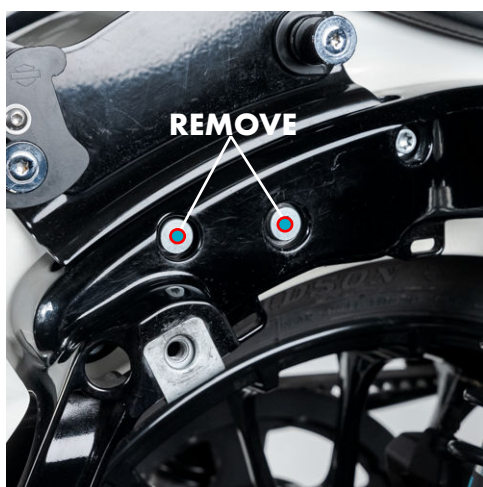

FIGURE B

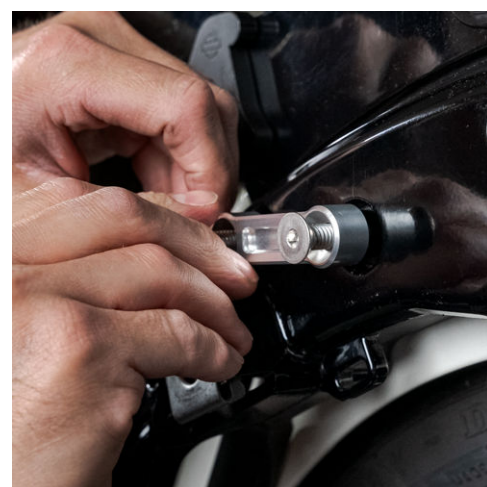

FIGURE C

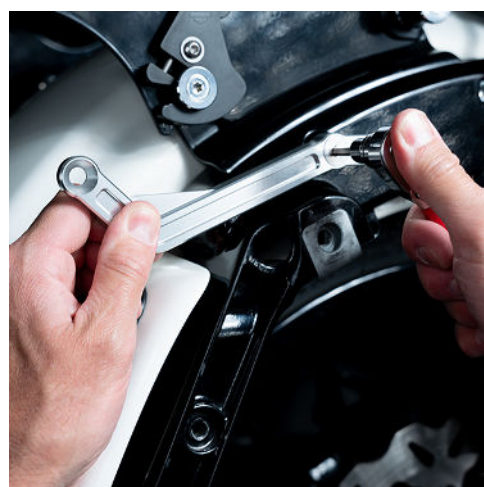

FIGURE D



FIGURE A

INSTALL INSTRUCTIONS-Continued



STEP THREE: INSTALL RESERVOIRS

- Identify the LH and RH reservoir clamps as shown in **FIGURE E**.
- Choose your preferred reservoir orientation, (COMPRESSION ADJUSTER FACING UP OR DOWN)
- Install the clamps onto reservoirs and center them as shown in **FIGURE F**.
- Apply blue threadlocker to the provided pinch screws and start them in the clamps. (DO NOT TIGHTEN AT THIS TIME)
- Route the reservoir hoses over the top of the fender struts and on the backside of the reservoir support arms with a 180 degree loop, placing them into the built in hose guides as shown in **FIGURE G**.
- Apply blue threadlocker to the provided mounting screws and mount the reservoir clamps to the support arms.
- Inspect and verify that there are no kinks in the hoses before tightening as shown in **FIGURE H**.
- Torque the 1/4"-20 pinch screws to 10 ft-lbs and the 5/16"-18 mounting screws to 22 ft-lbs.



FIGURE E



FIGURE F



FIGURE G



FIGURE H

CONFIGURATION #1

2014-2020 Models - mounting **WITHOUT** a solid mount four pack or **WITHOUT** the 4-point docking hardware. (plastic insert remains installed in the fender strut)

2014 to 2023 Models - mounting **WITH** the 4-point docking hardware installed.

add (1) of the included .058" washers to each rear mounting screw

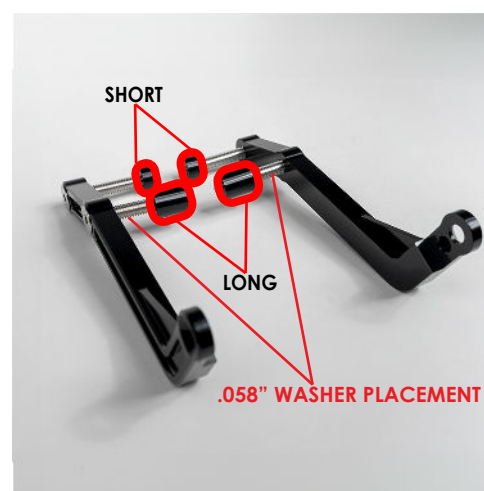

CONFIGURATION #2

2021 to 2023 Models - mounting **WITHOUT** a solid mount four pack or **WITHOUT** the 4-point docking hardware installed. (rubber insert remains installed in the fender strut)

